

BSC / MDA ALTERNATIVES

TYPE: HEAVY DUTY DUAL INTERNAL FAN ALTERNATOR

APPLICATIONS:

- Bus & Coach
- Truck
- Industrial
- Marine
- Refrigeration
- Air-conditioning

FEATURES:

- Direct drop-in replacements
- New modern design
- Improved performance vs old 8SC design
- Bi-directional rotation as standrd on 8SC / 8LHA replacements
- Improved speed and thermal rating.

OLD TYPES:

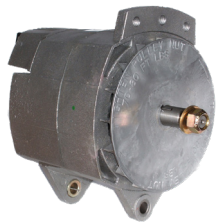

8SC

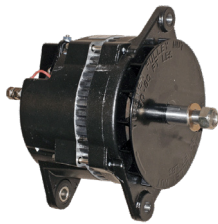

8LHA



MDA

SPECIFICATIONS:

- System voltage: 24/28 Volt
- Rating: 100A - 180A
- Frame size: 143mm (AVi143)
168mm (all other)
- Insulated return
- Rotation: Clockwise (AVi143 only)
Bi-directional (all other)
- Voltage sense option for the AVi143

PART NO. (SALES NO.)	OLD REF.	OUTPUT	ROT'n	TERMINALS	EXCITE	TYPE SPEED (max), TEMP (max)
AVi168A3174 (A168M174)	8SC3160V	24V / 150A Insulated	CW / CCW	B+(M8), B-(M6), L, W (M5)	Self-Excite	Battery charging 10000rpm, 105°C (max)
AVi168W3175 (A168M175B)	8SC3200V	24V / 150A Insulated	CW / CCW	B+(M8), B-(M6), L, W (M5)	12V / 24V Excite	Batteryless, AC 10000rpm, 125°C (max)
HEF318A14 (A318M014)	8SC3157V	24V / 180A Insulated	CW / CCW	B+(M8), B-(M6), L, W (M5)	Self-Excite	Battery charging 10000rpm, 105°C (max)
AVi2110A3159 (A211M159)	8SC3133U	24V / 110A Insulated	CW / CCW	B+(M8), B-(M6), L, W (M5)	Self-Excite	Battery charging 10000rpm, 105°C (max)
AVi2110E3127 (A211J127)	8LHA3096U	24V / 110A Insulated	CW / CCW	B+(M8), B-(M6), L, W (M5)	Self-Excite	Battery charging 10000rpm, 110°C (max)
AVi143J3004E (A143J304E)	MDA3929, MDA3927 MDA3946	24V / 100A Insulated	CW	B+(M8), B-(M6), L, W (M5)	Self-Excite, Voltage sense	Battery charging 12000rpm, 105°C (max)

NEW TYPES:



AVi2110A3159
AVi168A3174
AVi168W3175
HEF318A14

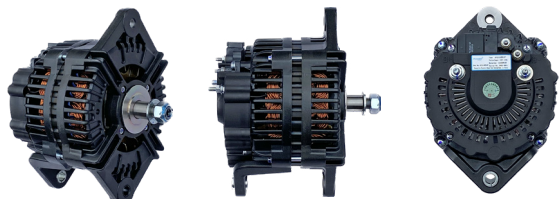

AVi2110E3127



AVi143J3004E

PERFORMANCE COMPARISON

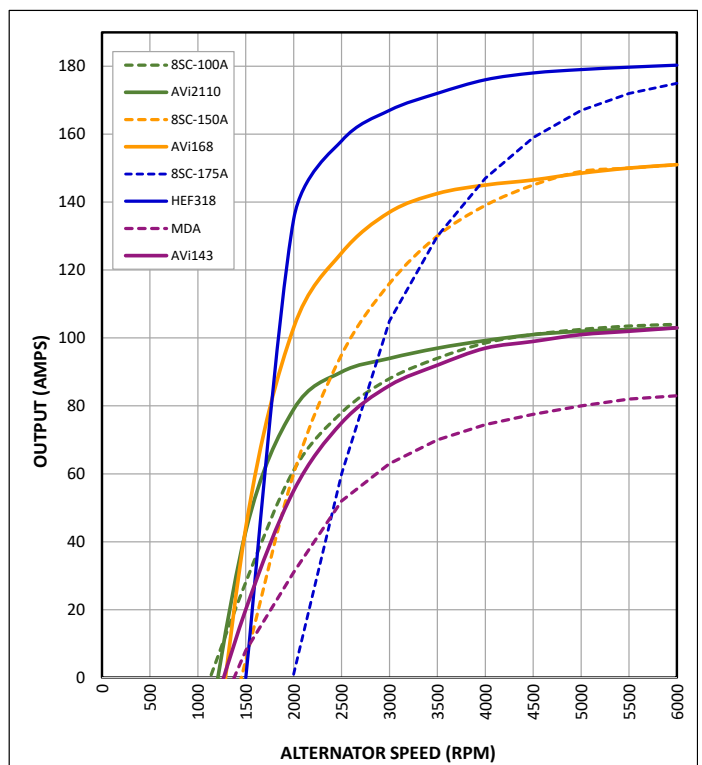

BSC / MDA ALTERNATIVES

TYPE: HEAVY DUTY DUAL INTERNAL FAN ALTERNATOR

WIRING DIAGRAMS

8SC replacement options:

AVi2110A3159 (8SC3133U replacement)

AVi168A3174 (8SC3160V replacement)

HEF318A14 (8SC3157V replacement)

Replacement options are self-excited machines and can be used on direct battery charging applications only.

These cannot be used on applications with split-charging systems.

The alternators must be connected directly to the batteries to enable excitation.

Old 8SC type are IGN excite and can be used with split-charging systems where the alternators are not connected directly to batteries.

AVi143J3004E (MDA3927, MDA3929, MDA3946 replacement)

This alternator is self-excited and has voltage sense functionality and split charging capability.

Note the appropriate wiring diagram for various applications:

Sense not required (single battery charging) > Link sense terminal to alternator B+ (supplied with alternator).

Sense required (single battery charging) > Remove sense / alternator B+ link wire supplied with alternator.

Link sense terminal direct to battery +ve terminal.

Split charging (dual battery charging) > Remove sense / alternator B+ link wire supplied with alternator.

Link sense terminal to battery +ve of the split charger.

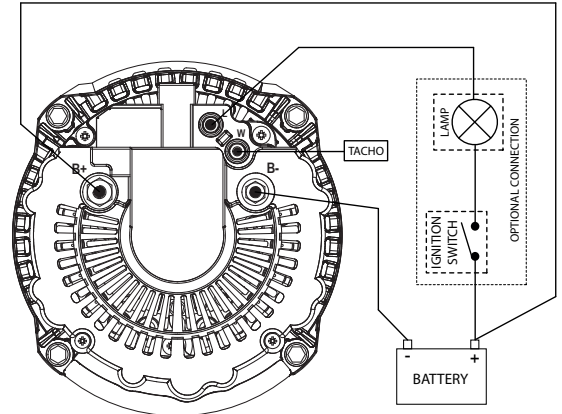

8SC Wiring Diagram

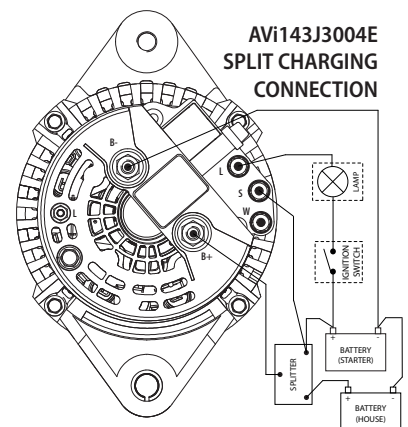
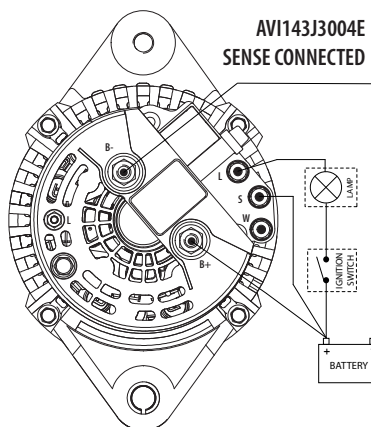
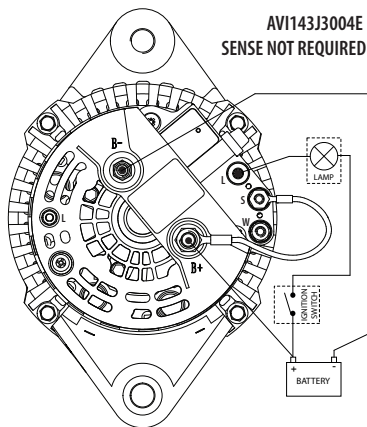

SIZE COMPARISON

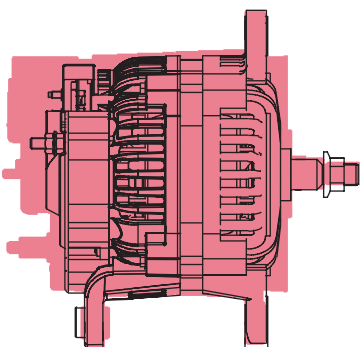

8SC vs AVi168 / AVi2110A3159
HEF318A14

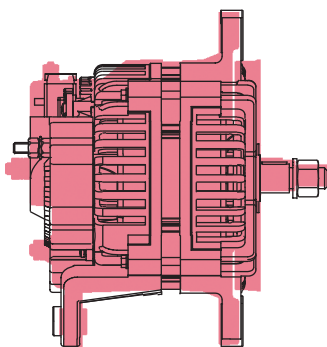

8LHA vs AVi2110E3127

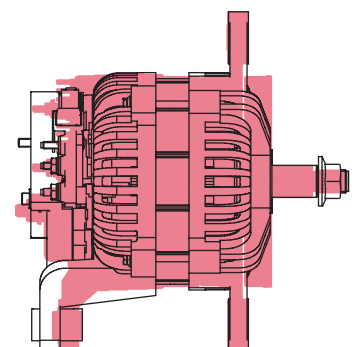

MDA vs AVi143J3004E

For any queries on compatibility, technical details and wiring please contact your Prestolite representative.